

BLOC DE SALLE DE BAINS

45cm
17 23/32"
70cm
27 9/16"
3,4cm
1 11/32"

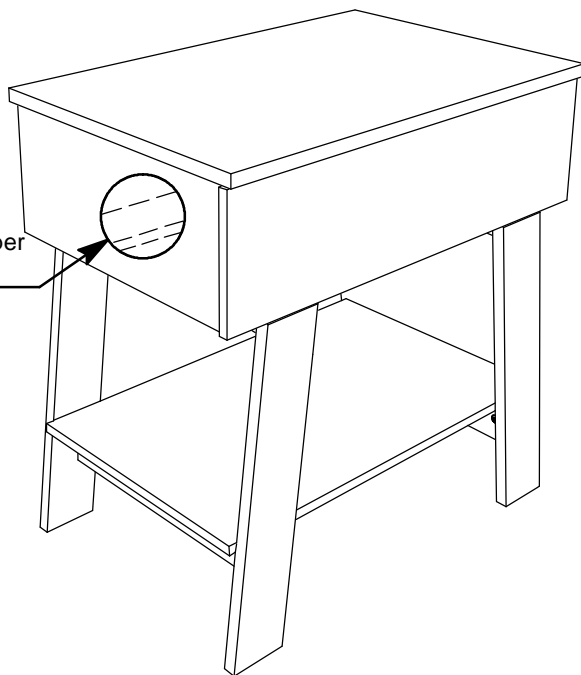
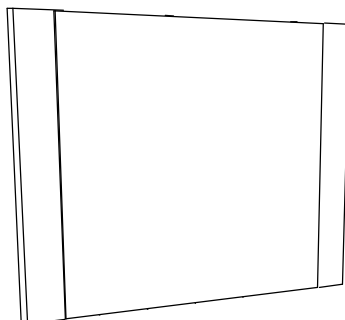

Attention: il est interdit de couper la traverse arriere (pièce 3)

82,4cm
32 7/16"
80,1cm
31 17/32"
53cm
20 55/64"

FR Remerciements :

Nous vous remercions d'avoir choisi un meuble créé et fabriqué par Ekipa et espérons qu'il vous donnera entière satisfaction.

EN Thanks :

Thank you for choosing furniture designed and manufactured by Ekipa. We hope you are totally satisfied your purchase.

DE Danksagung:

Wir danken Ihnen für den Kauf eines Frankreich von der Ekipa entworfenen und hergestellten Möbelstücks und hoffen, dass Sie es zu Ihrer vollkommenen Zufriedenheit finden werden.

ES Agradecimientos :

Les damos las gracias por haber elegido un mueble diseñado y fabricado por el Ekipa y esperamos que sea de su total agrado.

PT Agradecimentos :

Obrigado por ter escolhido um móvel concebido e fabricado pelo Ekipa, esperando que seja do seu inteiro agrado.

IT Ringraziamenti:

Grazie per avere scelto un mobile progettato e fabbricato dal Ekipa. Speriamo soddisfatti appieno le vostre esigenze.

NL Bedankje:

Wij bedanken u voor de aankoop van een door de Ekipa ontworpen en vervaardigd meubel en hopen dat u er veel plezier aan zult beleven.

CZ Poděkování:

Děkujeme, že jste si vybrali nábytek navržený a vyrobený společností Ekipa. Doufáme, že budete svým nákupem naprosto spokojeni.

HU Köszönet:

Köszönjük, hogy a Ekipa által létrehozott és gyártott bútort választott, reméljük, hogy elégedett lesz a termékkel.

PL Podziękowania:

Dziękujemy za wybór mebli stworzonych i wyprodukowanych przez Ekipa. Mamy nadzieję, że będziecie Państwo w pełni zadowoleni z zakupu.

RO Mulțumiri:

Vă mulțumim că ați ales un articol de mobilier conceput și fabricat de Ekipa și sperăm că veți fi pe deplin satisfăcuți de acesta.

RU Благодарность:

Мы благодарим вас за то, что вы выбрали мебель, созданную и произведенную Групп Паризо, и надеемся, что вы будете полностью удовлетворены нашей продукцией.

SK Pod'akovanie:

Ďakujeme, že ste si vybrali nábytok navrhnutý a vyrobený spoločnosťou Ekipa. Dúfame, že budete svojím nákupom absolútne spokojní.

TR Teşekkür ederiz:

Ekipa tarafından tasartanan ve üretilen bu mobilyayı seçtiğiniz için teşekkür ederiz. Ürünümüzden memnun kalmanhizi ümit ederiz

AR شكر:

نشكركم لاختياركم هذه القطعة من التصميم وتصنيع مجموعة باريزو Ekipa ونتمنى أن تتل رضاهم.

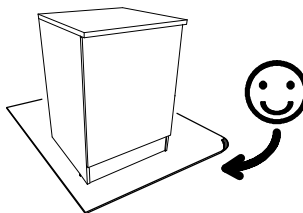
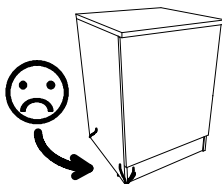
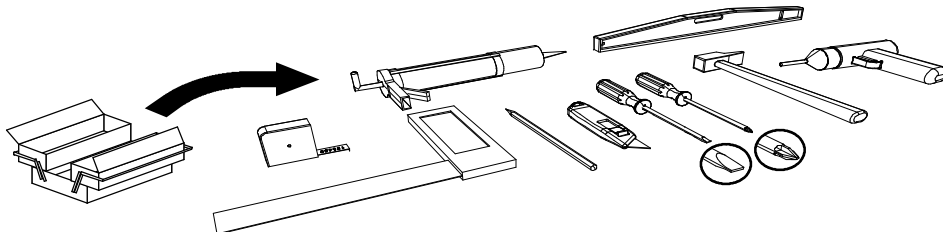





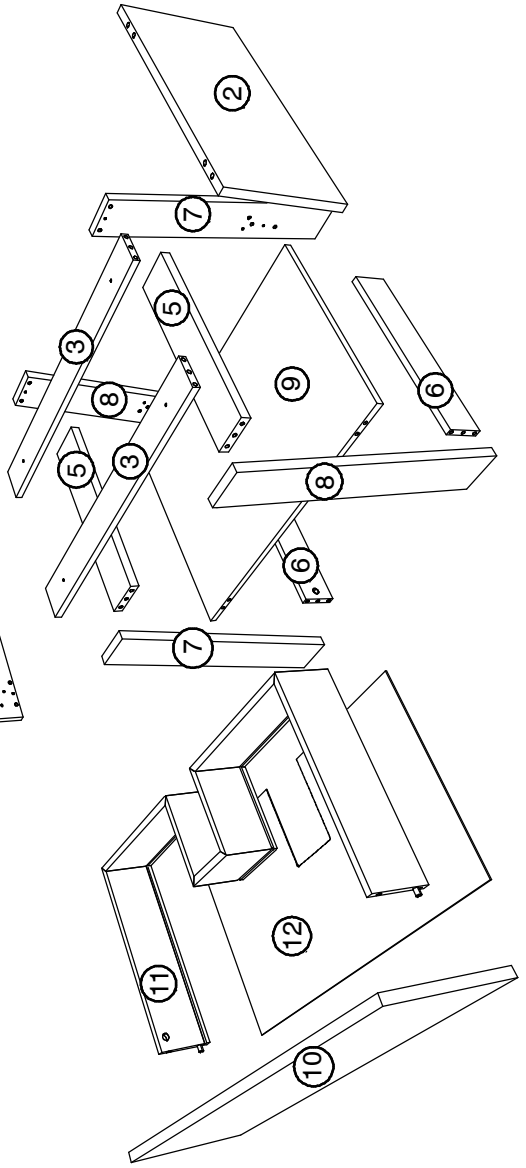
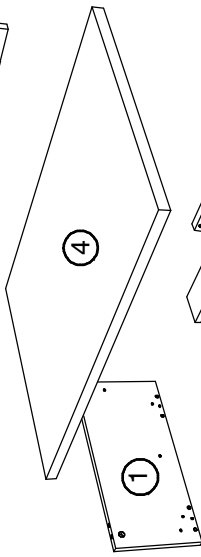
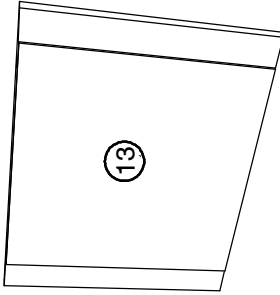



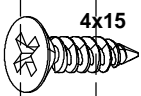
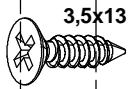

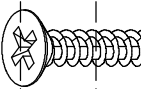



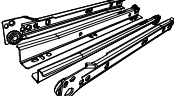

contact@parisot.com

Rep	Qté	mm		inch	
01	1	504	230	19 27/32	9 1/16
02	1	504	230	19 27/32	9 1/16
03	2	738	80	29 1/16	3 5/32
04	1	801	530	31 17/32	20 55/64
05	2	475	97	18 45/64	3 13/16
06	2	475	81	18 45/64	3 3/16
07	2	585	100	23 1/32	3 15/16
08	2	585	100	23 1/32	3 15/16
09	1	750	475	29 17/32	18 45/64
10	1	797	222	31 3/8	8 47/64
11	1	1763	100	69 13/32	3 15/16
12	1	700	349	27 9/16	13 47/64
13	1	700	450	27 9/16	17 23/32

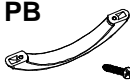

0 1 cm 2 3

VAF8		4x15	x4
VG		3,5x13	x6
BWF			x4
FO			x16
WF			x4
ADM			x32

XB 	NC x1 	
XG 	BR 	x8 x1
PAS 	EP 	BQS 
x1 x2 x4		
CF 	AI 	BSD 
x1 x20 x20		
PB 	BZG 	BSD 
x1 x2 x2		

1

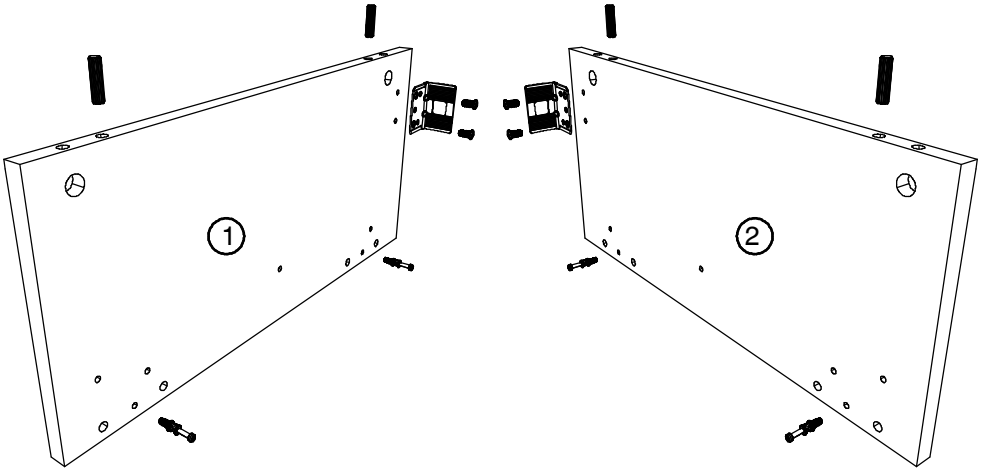
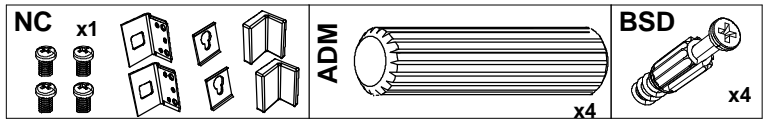

2

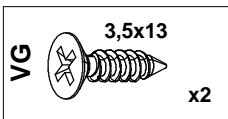
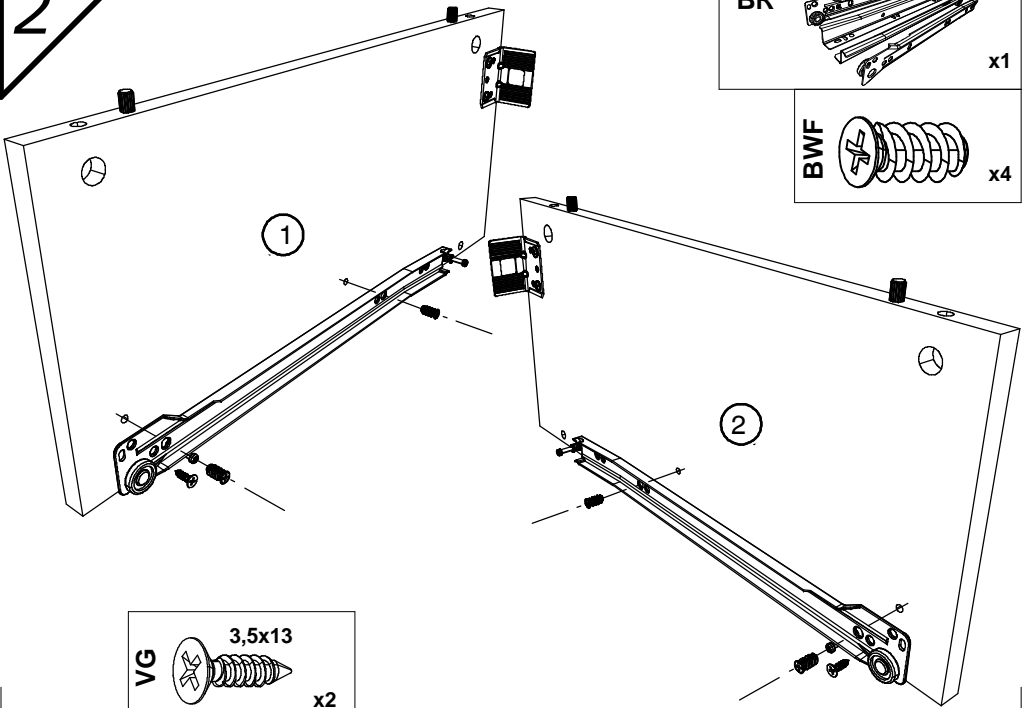
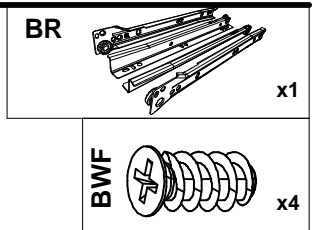

3

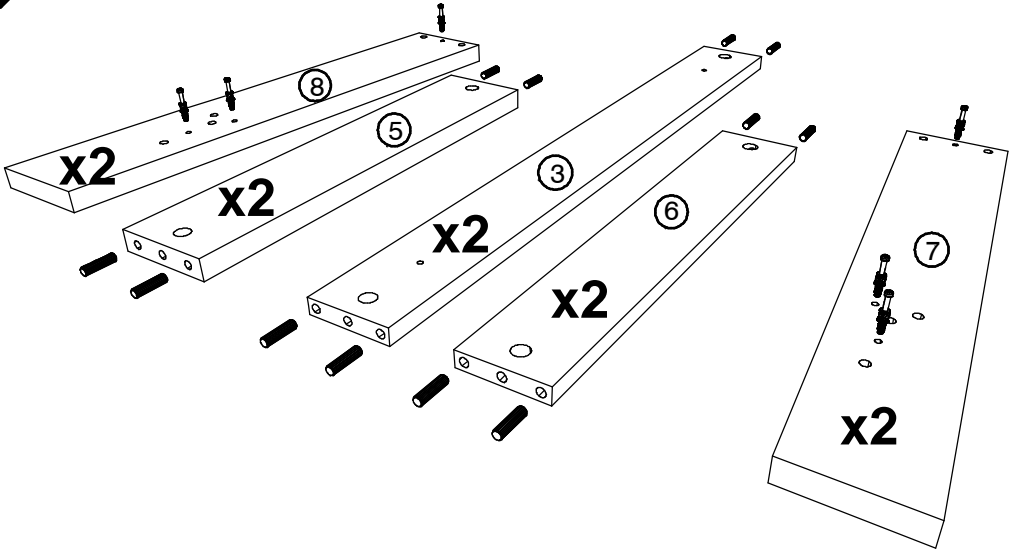

4

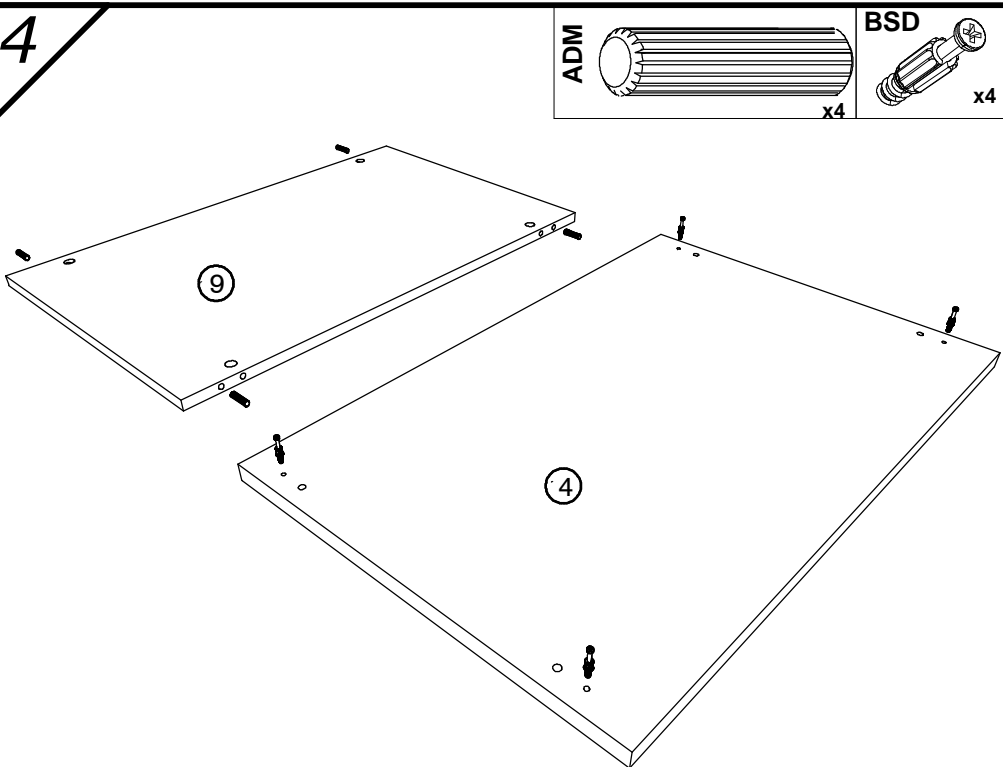

5

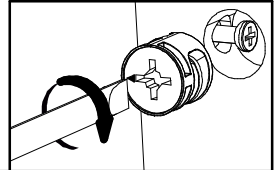
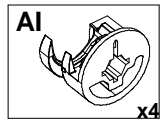
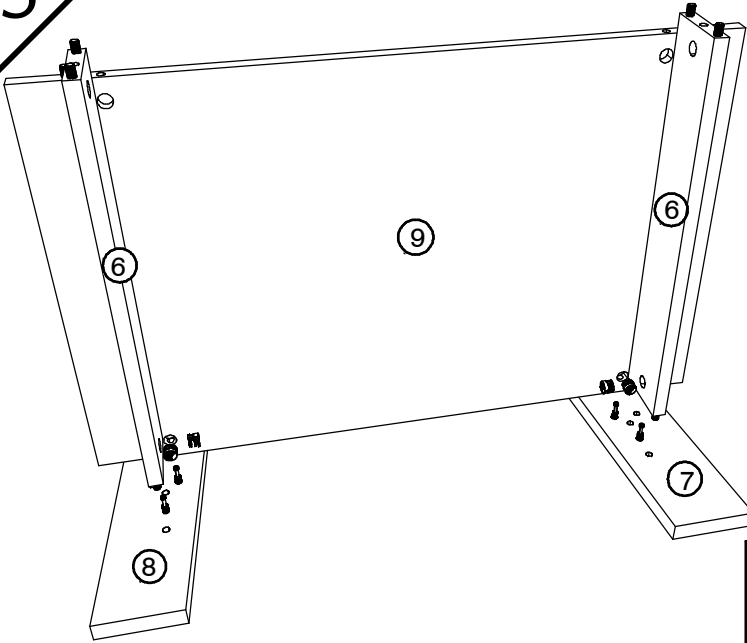

6

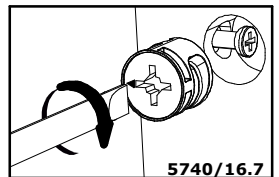
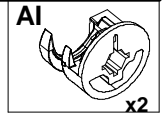
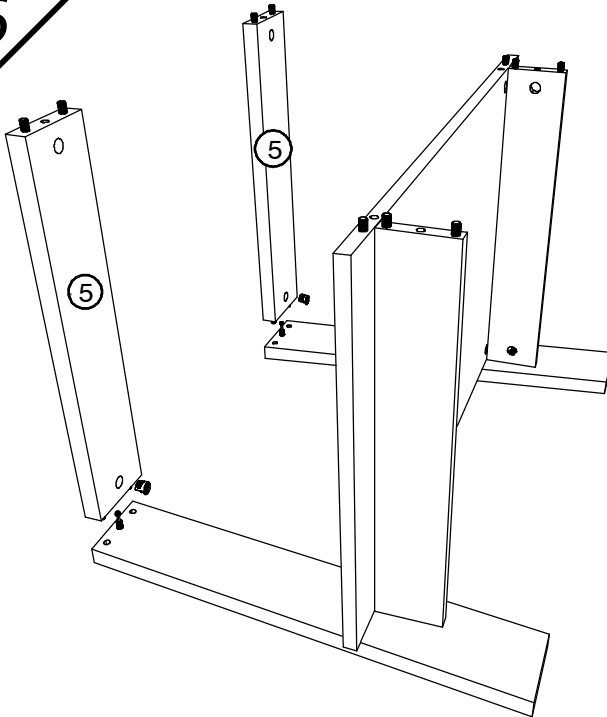

7

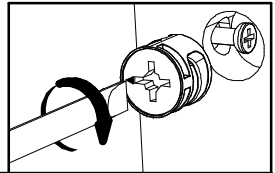
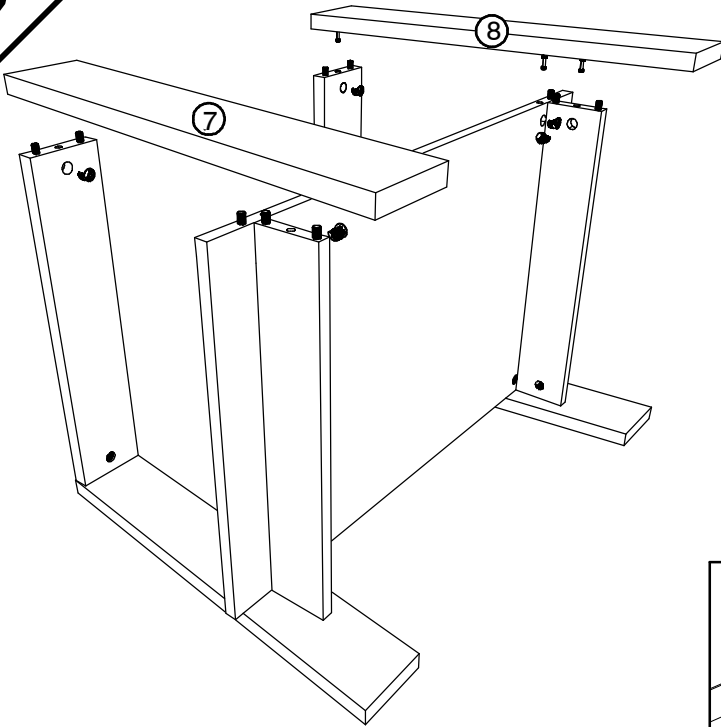
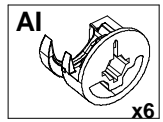

8

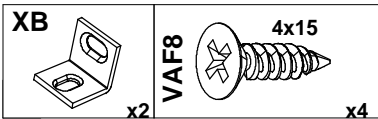
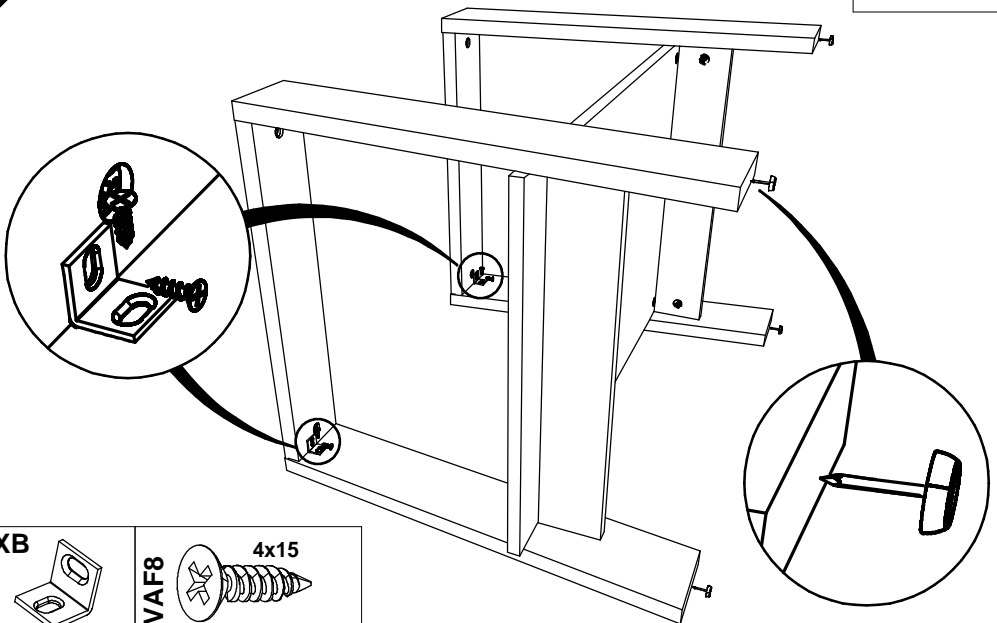
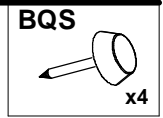

9

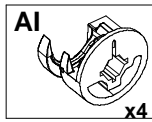
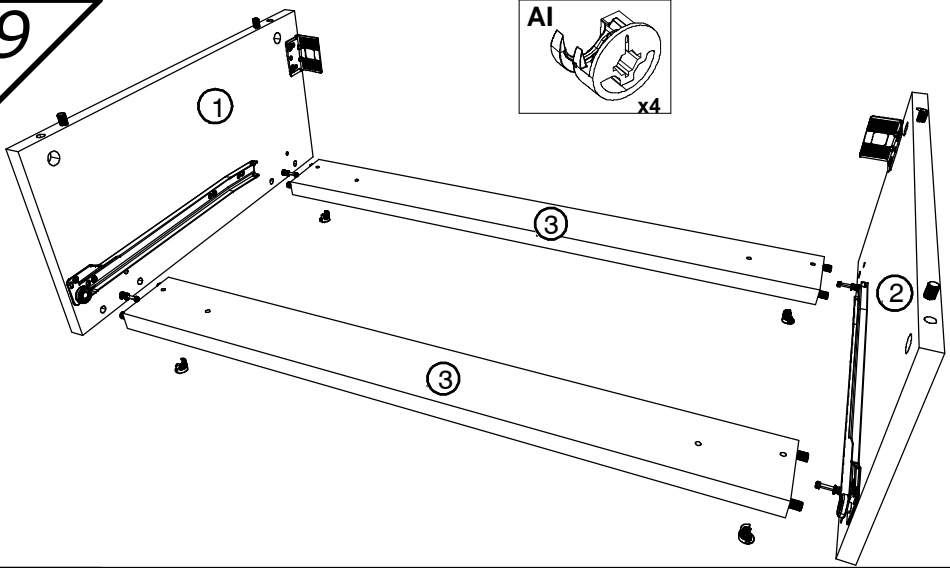

10

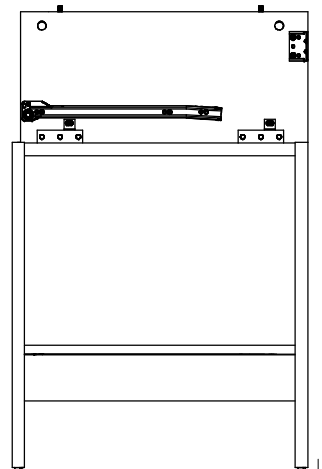
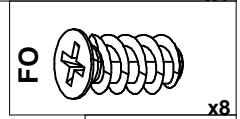
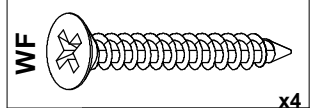
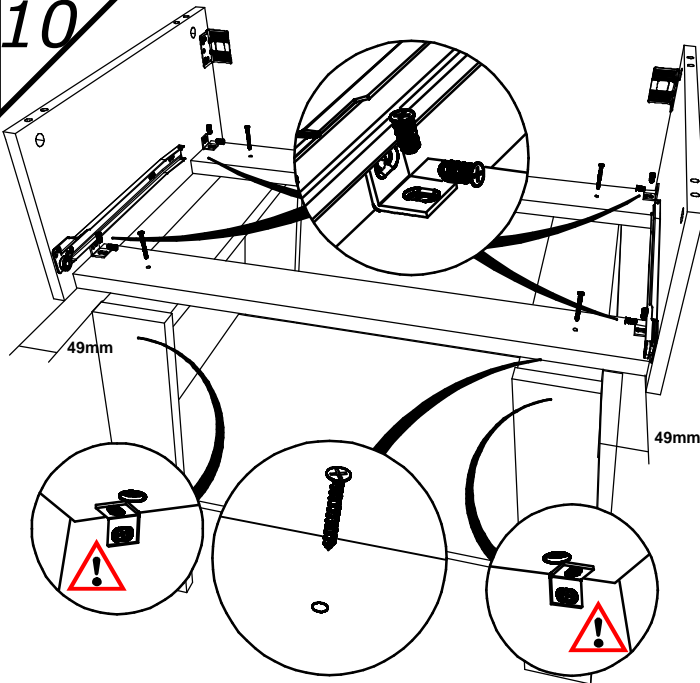

11

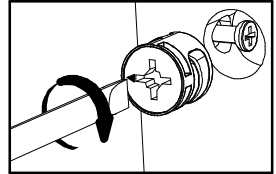
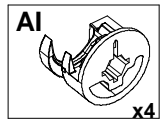
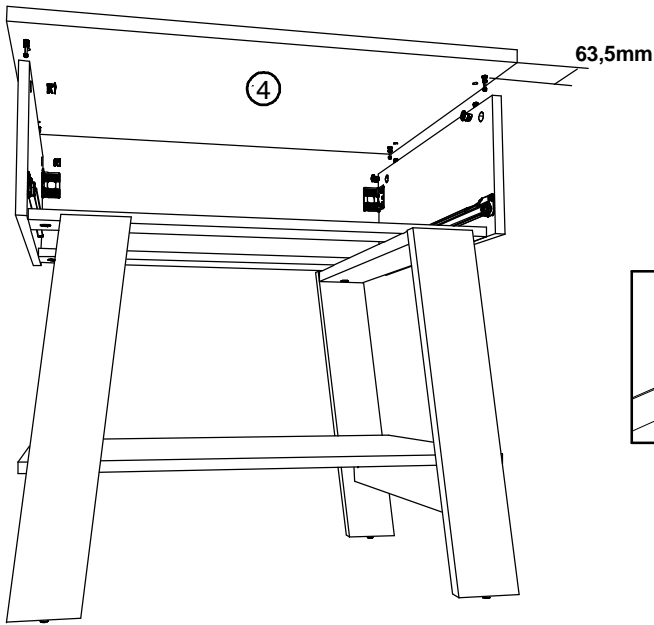

12

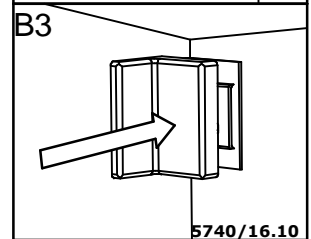
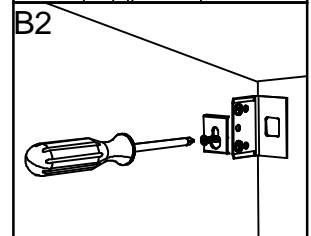
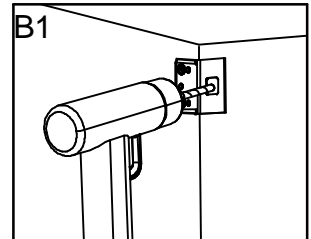
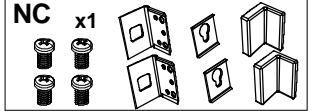
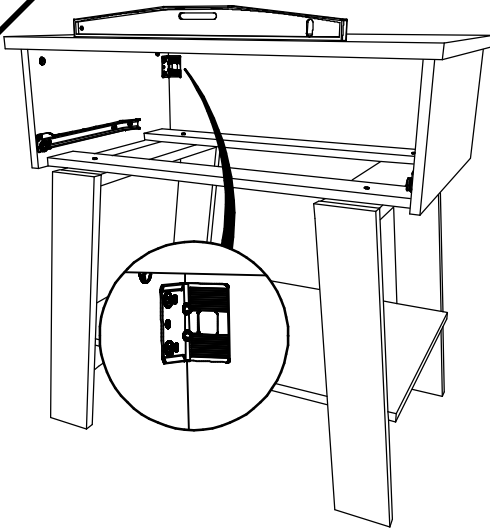

FR Pour votre sécurité : Fixation du meuble au mur
 Attention, la fixation doit être réalisée par une personne compétente car cela nécessite des chevilles adaptées à la nature de votre mur.

EN For your safety: the unit should be secured to the wall.
 NB this should be carried out by a competent person as you must use the right rawplug for your type of wall.

13

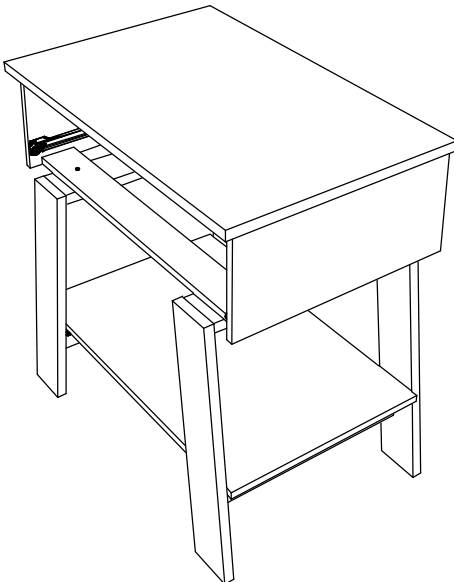
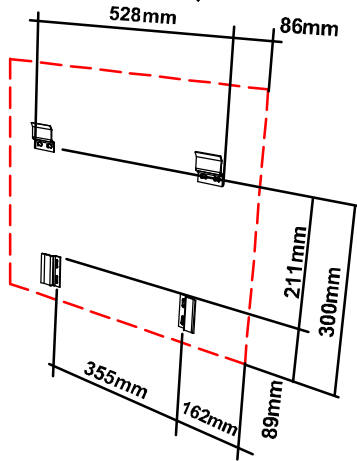
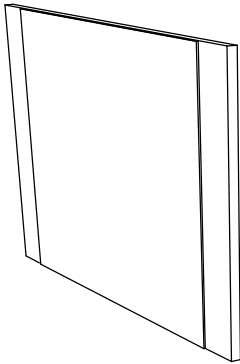
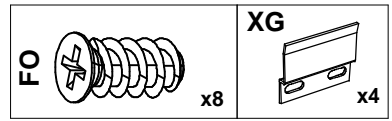
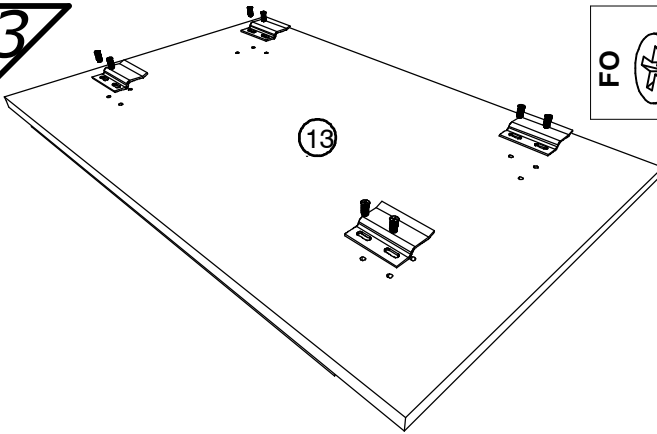

FR Pour votre sécurité : Fixation du meuble au mur
Attention, la fixation doit être réalisée par une personne compétente
car cela nécessite des chevilles adaptées à la nature de votre mur.

EN For your safety: the unit should be secured to the wall.
NB this should be carried out by a competent person as you must
use the right rawplug for your type of wall.

14

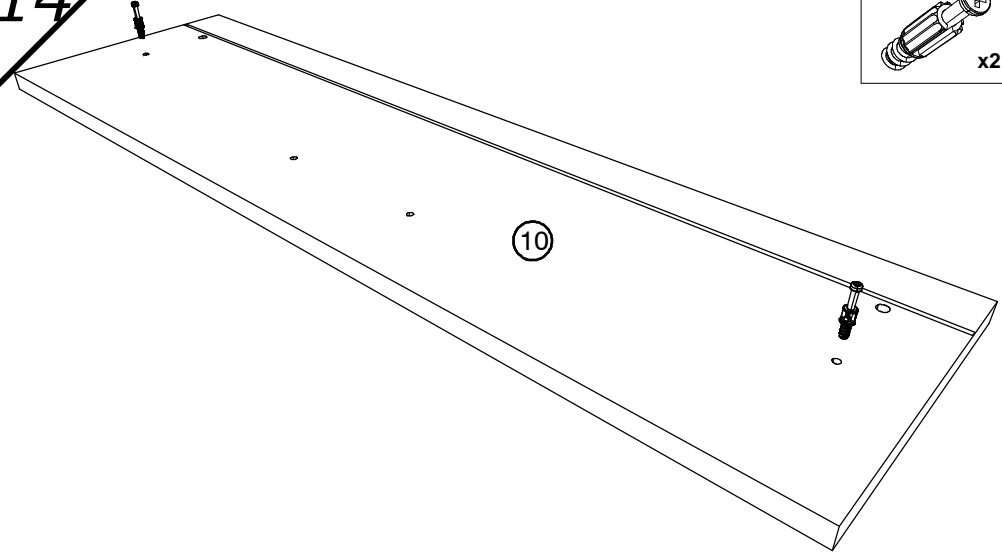
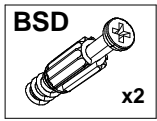

15

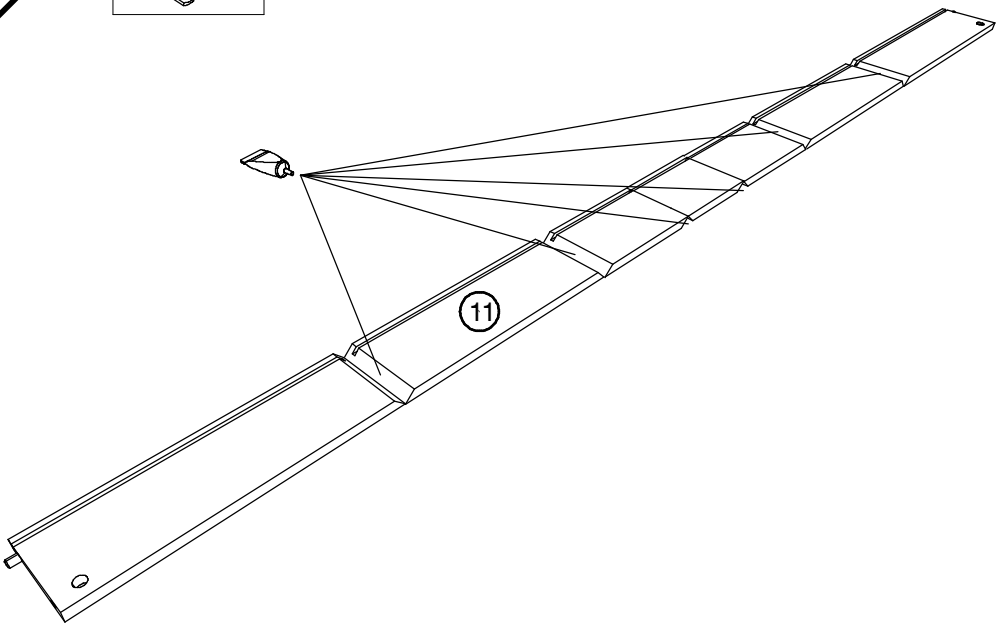
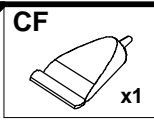

16

BZG

x2

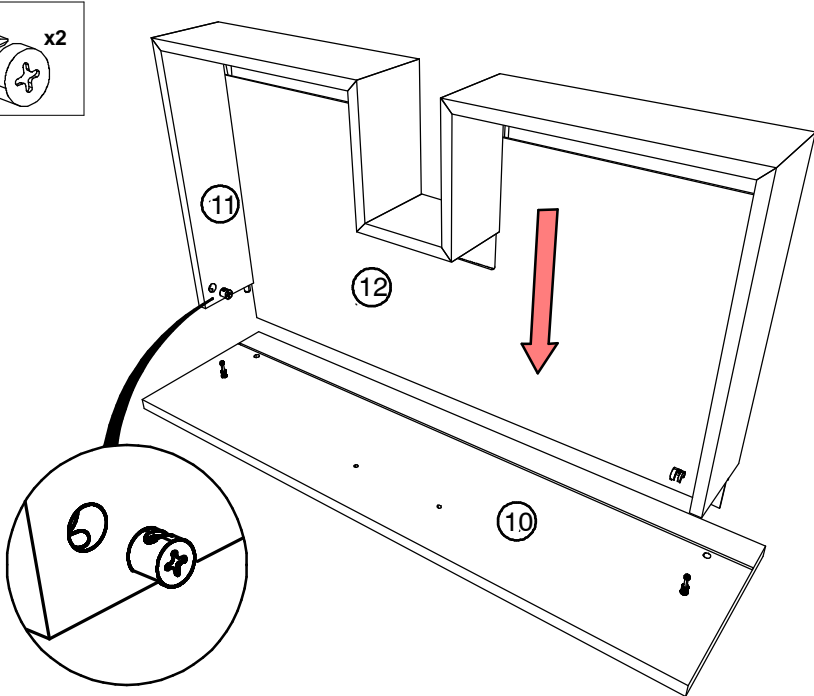

17

VG

3,5x13

x4

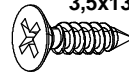

EP

x2

